



**TITLE:**  
**SPECIFICATION FOR  
11 kV EXPULSION FUSE  
CUT-OUT  
(Drop out type)**

Doc. No.	KP1/6C/13/TSP11/017
Issue No.	2
Revision No.	0
Date of Issue	2016-06-03
Page 1 of 19	

## TABLE OF CONTENTS

### 0.1 Circulation List

### 0.2 Amendment Record

## FOREWORD

1. SCOPE
2. REFERENCES
3. TERMS AND DEFINITIONS
4. REQUIREMENTS
5. TESTS AND INSPECTION
6. MARKING AND PACKING
7. DOCUMENTATION

### ANNEX A: SCHEDULE OF GUARANTEED TECHNICAL PARTICULARS FOR OFFERED CONDUCTORS

*(to be filled and signed by the Manufacturer and submitted together with relevant copies of the Manufacturer's catalogues, brochures, drawings, technical data & calculations, sales records for past five years, four customer reference letters, details of manufacturing capacity, the manufacturer's experience, copies of complete type test reports and accreditation certificate to ISO/IEC 17025 for the third party testing laboratory for tender evaluation, all in English Language)*

### ANNEX B: LIST OF CONTRACTORS

Issued by: Head of Section ,Standards Development

Authorized by:, Manager ,Standards

Signed:

Signed:

Date: 2016-06-03

Date: 2016-06-03



**TITLE:**  
**SPECIFICATION FOR  
 11 kV EXPULSION FUSE  
 CUT-OUT  
 (Drop out type)**

Doc. No.	KP1/6C/13/TSP11/017
Issue No.	2
Revision No.	0
Date of Issue	2016-06-03
Page 2 of 19	

**0.1 Circulation List**

COPY NO.	COPY HOLDER
1	Manager, Standards Department
Electronic copy (pdf) on KPLC server currently: <a href="http://172.16.1.40/dms/browse.php?fFolderId=23">http://172.16.1.40/dms/browse.php?fFolderId=23</a>	

**0.2 Amendment Record**

Rev No.	Date (YYYY-MM-DD)	Description of Change	Prepared by (Name & Signature)	Approved by (Name & Signature)
Issue 0	2014-09-05	Replaces issue No. 1	Michael Apudo	Eng. S Kimitei
		1. Clause 4.3 Table 2: Changed creepage distance from 320mm to 300mm		
		2. Clause 5.6: Replaced "manufacturer" with "supplier"		
		3. Foreword: Replaced "manufacturer" with "supplier"		

**Issued by:** Head of Section ,Standards Development

**Authorized by:** , Manager ,Standards

**Signed:**

**Signed:**

**Date:** 2016-06-03

**Date:** 2016-06-03



**TITLE:**  
**SPECIFICATION FOR  
11 kV EXPULSION FUSE  
CUT-OUT  
(Drop out type)**

Doc. No.	KP1/6C/13/TSP11/017
Issue No.	2
Revision No.	0
Date of Issue	2016-06-03
Page 3 of 19	

**FOREWORD**

This specification has been prepared by the Standards Department of the Kenya Power & Lighting Company Ltd (KPLC) and it lays down requirements for 11kV Expulsion Fuse Cut-out (drop out type). The specification is intended for use by KPLC in purchasing the fuse cutouts.

The supplier shall submit information which confirms the manufacturer's satisfactory service experience with products which fall within the scope of this specification.

**1. SCOPE**

- 1.1. This specification is for single phase expulsion fuse cut-out (drop out type) to be used outdoors on 11kV, 50Hz ac system for protection and isolation of substation apparatus and sectionalizing purposes. The expulsion fuse cut-out shall incorporate the fuse mount (fuse base) and its fuse-carrier.
- 1.2. The specification also covers inspection and test of the fuse cutouts as well as schedule of Guaranteed Technical Particulars to be filled, signed by the manufacturer and submitted for tender evaluation.
- 1.3. The specification stipulates the minimum requirements for fuse cutouts acceptable for use in the company (KPLC) and it shall be the responsibility of the Manufacturer to ensure adequacy of the design, good workmanship and good engineering practice in the manufacture of the fuse cutouts for KPLC.

The specification does not purport to include all the necessary provisions of a contract.

**2. REFERENCES**

The following standards contain provisions which, through reference in this text constitute provisions of this specification. Unless otherwise stated, the latest editions (including amendments) apply.

- ISO 1461: Hot dip galvanized coatings on fabricated iron and steel articles – Specifications and Test Methods.
- IEC 60282: High voltage fuses - Part 2: Expulsion and similar fuses
- IEC 60507: Artificial pollution tests on high-voltage insulators to be used on a.c. systems is applicable for the determination of the power frequency
- IEC 60437: Radio interference test on high-voltage insulators

**Issued by:** Head of Section ,Standards Development

**Authorized by: ,** Manager ,Standards

**Signed:**

**Signed:**

**Date:** 2016-06-03

**Date:** 2016-06-03



TITLE:

**SPECIFICATION FOR  
11 kV EXPULSION FUSE  
CUT-OUT  
(Drop out type)**

Doc. No.

KP1/6C/13/TSP11/017

Issue No.

2

Revision No.

0

Date of Issue

2016-06-03

Page 4 of 19

IEC 61284: Overhead lines—Requirements and tests for fittings,

IEC 60383: Insulators for overhead lines with a nominal voltage above 1000 V --Part 1: Ceramic or glass insulator units for a.c. systems — Definitions, test methods and acceptance criteria

IEC 61109: Composite insulators for a.c. overhead lines with a nominal voltage greater than 1000V – Definitions, test methods and acceptance criteria.

ANSI C 37.42: Specification for distribution cut outs and fuse links

ANSI C 37.41: Standard design tests for high voltage fuses, distribution enclosed single-pole air switches, fuse disconnecting switches and accessories

### 3. TERMS AND DEFINITIONS

For the purpose of this specification, the terms and definitions given in the reference standards shall apply.

### 4. REQUIREMENTS

#### 4.1. Service and System Conditions

4.1.1. The fuse cutout shall be suitable for continuous operation outdoors in tropical areas at:

- a) Altitude: up to 2,200m above sea level;
- b) Temperature: average of +30°C with a minimum of -1°C and max +40 °C;
- c) Humidity: up to 95%;
- d) Pollution: Design pollution level to be taken as "Heavy" (Pollution level III) for inland and "Very Heavy" (Pollution level IV) for coastal applications in accordance with IEC 60815.
- e) Isokeraunic level: 180 thunderstorm days per year

4.1.2. The fuse cutout shall be suitable for a.c. system with system highest voltage of 12kV and frequency of 50Hz as per Table 1 below.

**Table 1: System Characteristics**

No	Characteristics	Rating
(a)	Nominal Voltage	11kV
(b)	System highest Voltage	12kV
(c)	System frequency	50 Hz

Issued by: Head of Section ,Standards Development

Authorized by:, Manager ,Standards

Signed:

Signed:

Date: 2016-06-03

Date: 2016-06-03



**TITLE:**  
**SPECIFICATION FOR  
11 kV EXPULSION FUSE  
CUT-OUT  
(Drop out type)**

Doc. No.	KP1/6C/13/TSP11/017
Issue No.	2
Revision No.	0
Date of Issue	2016-06-03
Page 5 of 19	

No	Characteristics	Rating
(d)	Number of phases	3
(e)	Method of earthing	Non effectively earthed
(f)	System faults level	12.5 kA rms

## 4.2. DESIGN AND CONSTRUCTION

### 4.2.1. General

- 4.2.1.1. The expulsion fuse cutout shall be designed and manufactured to IEC 60282-2 and the requirements of this specification
- 4.2.1.2. The expulsion fuse cutout shall be supplied as a complete unit incorporating the fuse mount (fuse base) with its fuse-carrier.
- 4.2.1.3. All current carrying parts shall be of electrolytic high conductivity copper with the contacts of hard drawn copper and silver-plated.
- 4.2.1.4. The fuse cutout shall withstand the specified impulse and power frequency voltages in all applicable mounting positions including angle mounting.

### 4.2.2. Operation

- 4.2.2.1. It shall not be possible to close the fuse carrier without the top cap fitted. The disconnecter fuse units shall be designed and constructed such that on closing the fuse carrier-fuse link, no additional stress shall be applied to the fuse link which could cause it to fail.
- 4.2.2.2. To allow for interchangeability of the fuse carriers between the fuse units from different manufacturers, the distance between contacts shall be strictly in accordance with Fig. 1.
- 4.2.2.3. Lifting rings of 25 mm nominal internal diameter shall be provided on the bottom end and on the top of the fuse tube to enable the removal and replacement of the fuse tube using a standard operating rod fitted with a hook-link stick. When an expulsion drop-out disconnecter fuse is mounted on a pole the fuse carrier shall not hit the pole during opening operation.
- 4.2.2.4. The top contact support of the disconnecter fuse shall be provided with hooks suitable for attachment of a portable load breaking tool.

Issued by: Head of Section ,Standards Development

Authorized by:, Manager ,Standards

Signed:

Signed:

Date: 2016-06-03

Date: 2016-06-03





**TITLE:**  
**SPECIFICATION FOR  
11 kV EXPULSION FUSE  
CUT-OUT  
(Drop out type)**

Doc. No.	KP1/6C/13/TSP11/017
Issue No.	2
Revision No.	0
Date of Issue	2016-06-03
Page 6 of 19	

#### 4.2.3. Mounting

The angle of inclination of the disconnecter fuse carrier shall be sufficient to allow ease of operation with due regard to the safety of the operator. The disconnecter shall be capable of being mounted on either poles or cross-arms.

##### a) Steel Cross-arm Mounting

- (i) A hole shall be provided in the mounting bracket to allow the cutout to be fixed to the top of the cross-arm by means of a M20 bolt vertically through the cross-arm with its centre line located 50mm from the face of the cross-arm.
- (ii) A suitable locking arrangement shall be provided to prevent rotation of the disconnecter about the mounting bolt when in service.

##### b) Pole Mounting

- (i) A hole shall be provided in the mounting bracket to allow the disconnecter to be fixed to a pole by a M20 bolt or fixed to a clamp in case of round concrete pole.
- (ii) A further hole shall be provided for an M16 coach screw connection to the pole to prevent rotation of the disconnecter about the mounting bolt when in service.

#### 4.2.4. Contacts

4.2.4.1. All electrical contact surfaces shall be silver plated to ensure that the thickness of plating provides durability of the contact surfaces over a service life of 35 years.

4.2.4.2. All contacts shall be greased, self-aligning and shall have wiping action to remove oxide or other contamination on the contact surfaces and constructed to eliminate arcing damage to the main contacts. As the hinge and fuse carrier may be subject to operation from an off-center position they shall be of robust construction to align correctly under this condition.

#### 4.2.5. Terminal Connections

4.2.5.1. A terminal connection shall be provided on both the supply and load sides of the disconnecter fuse unit and shall provide for a lug connection using a single M10 bolt, and also bolted clamp connection capable of accommodating a conductor range from 12 mm to 20 mm diameter.

4.2.5.2. The connection shall be designed so that the conductor can be removed using live-line techniques which do not require a bolt to be held during the untightening process i.e. the bolt is held captive in the terminal fitting to prevent rotation of the bolt at any stage when untightening and shall not become loose once the nut is removed.

Issued by: Head of Section ,Standards Development

Authorized by:, Manager ,Standards

Signed:

Signed:

Date: 2016-06-03

Date: 2016-06-03



**TITLE:**  
**SPECIFICATION FOR  
11 kV EXPULSION FUSE  
CUT-OUT  
(Drop out type)**

Doc. No.	KP1/6C/13/TSP11/017
Issue No.	2
Revision No.	0
Date of Issue	2016-06-03
Page 7 of 19	

4.2.5.3. The connections shall be designed for use with aluminium, copper, or steel conductors and to minimize the effects of electrolytic corrosion of dissimilar metals.

4.2.5.4. A bolted clamp shall meet the performance requirements of IEC 61284. Tunnel and U-Bolt type clamps are not acceptable.

**4.2.6. Vibration**

When the fuse link is intact and correctly inserted, the carrier shall latch securely when closed and shall not be dislodged from the fuse contacts by vibration or wind pressure. The carrier shall not dislodge from the bottom hinge in the opening operation, or in the open position during wind or vibration conditions.

**4.2.7. Bird/Fauna/Vermin Proofing**

The insulator/mounting bracket combination shall be designed in such a manner so as to minimize the risk of flashover due to birds, and other wildlife, without the use of plastic or rubber coverings. The fuse carrier design shall minimize the possibility of insect nests being formed in the fuse carrier.

**4.2.8. Fuse Link Installation**

4.2.8.1. A flipper spring mechanism shall be incorporated into the design of the fuse carrier to assist the fuse link ejection. The fuse link tail shall be held captive such that it does not make contact with the inner walls of the fuse carrier i.e. the flipper spring mechanism shall centrally locate the range of fuse link sizes from the smallest to the largest diameters, within the fuse carrier. Detailed drawings indicating the position of the flipper spring together with the smallest and largest fuse links when installed within the fuse carrier shall be provided with the bid.

4.2.8.2. Fuse link attachment to the fuse carrier trunnion must prevent binding of the fuse link on the thread. Further, the tail section of the fuse carrier trunnion shall be metal only i.e. this section shall NOT be covered by PVC or other material. The thumb screw or the attachment used to retain the fuse link shall be held captive in the unscrewed position.

**4.2.9. Earthing Attachment**

The bottom hinge section of the dropout disconnecter unit shall be provided with an earth attachment device satisfying the following requirements:

**Issued by: Head of Section ,Standards Development**

**Authorized by:, Manager ,Standards**

**Signed:**

**Signed:**

**Date: 2016-06-03**

**Date: 2016-06-03**

- a) Be capable of supporting the weight of the portable earthing cables (nominally 35kg) and not allow accidental detachment of the portable earths.
- b) Have a 1 second withstand current rating of 6kA (minimum).
- c) Provide a clearance of 500mm ((nominal) from the live parts to the earth attachment point.
- d) Be orientated in-line with the dropout disconnecter so that the device does not interfere with the operation of the unit or reduce the phase to phase clearances.

#### 4.2.10. Insulators

4.2.10.1. The insulator shall be a single piece, fully vitrified non-puncturable porcelain in accordance with IEC 60383-1 or a reinforced high temperature vulcanized (HTV) silicone rubber based on dimethyl siloxane, which exhibit hydrophobicity with the capability to transfer hydrophobicity to the layer of pollution as per IEC 61109. The preferred colour is BROWN.

4.2.10.2. The insulator shall be of adequate mechanical strength to withstand the loads applied during the opening and closing cycles. Details of the design features including the mechanical rating of the insulators and testing undertaken to meet these requirements shall be provided.

#### 4.3. RATING

The rating of the complete fuse cutout shall be as Table 2 below:

Table 2: Technical requirements for Fuse Cutout

Sn.	Particulars	Units	Ratings
1	Rated voltage	kV	11
2	Highest Voltage	kV	12
3	Rated continuous current	A	400
4	Insulation levels		
	a) Dry impulse withstand (1.2/50µs) voltage (positive and negative polarity) (peak)		
	(i) Across the isolating distance of the fuse base	kVpeak	95
	(ii) To earth and between poles	kVpeak	85
	b) Wet one (1) minute power frequency withstand voltage (rms)		
	(i) Across isolating distance of the fuse base	kVrms	38
	(ii) To earth and between poles	kVrms	32
5	Rated short circuit withstand current of fuse base and carrier	kA	16 (3 sec)
6	Radio interference voltage at 1 MHz	µV	200
7	Total creepage distance, 25mm/kV	mm	300

Issued by: Head of Section ,Standards Development

Authorized by:, Manager ,Standards

Signed:



Signed:

Date: 2016-06-03

Date: 2016-06-03





**TITLE:**  
**SPECIFICATION FOR  
11 KV EXPULSION FUSE  
CUT-OUT  
(Drop out type)**

Doc. No.	KP1/6C/13/TSP11/017
Issue No.	2
Revision No.	0
Date of Issue	2016-06-03
Page 9 of 19	

Sn.	Particulars	Units	Ratings
8	Mounting angle	degrees	10 - 20
9	Interrupting rating		
	(i) Symmetrical interrupting rating (minimum) rms	kA	8
	(ii) Asymmetrical interrupting rating (minimum) rms	kA	9.6
	(iii) X/R ration		4
10	No. of operations before service, replacement of:	contacts	
		moving parts	

THIS PAGE LEFT INTENTIONALLY BLANK

Issued by: Head of Section ,Standards Development

Authorized by:, Manager ,Standards

Signed:

Signed:

Date: 2016-06-03

Date: 2016-06-03

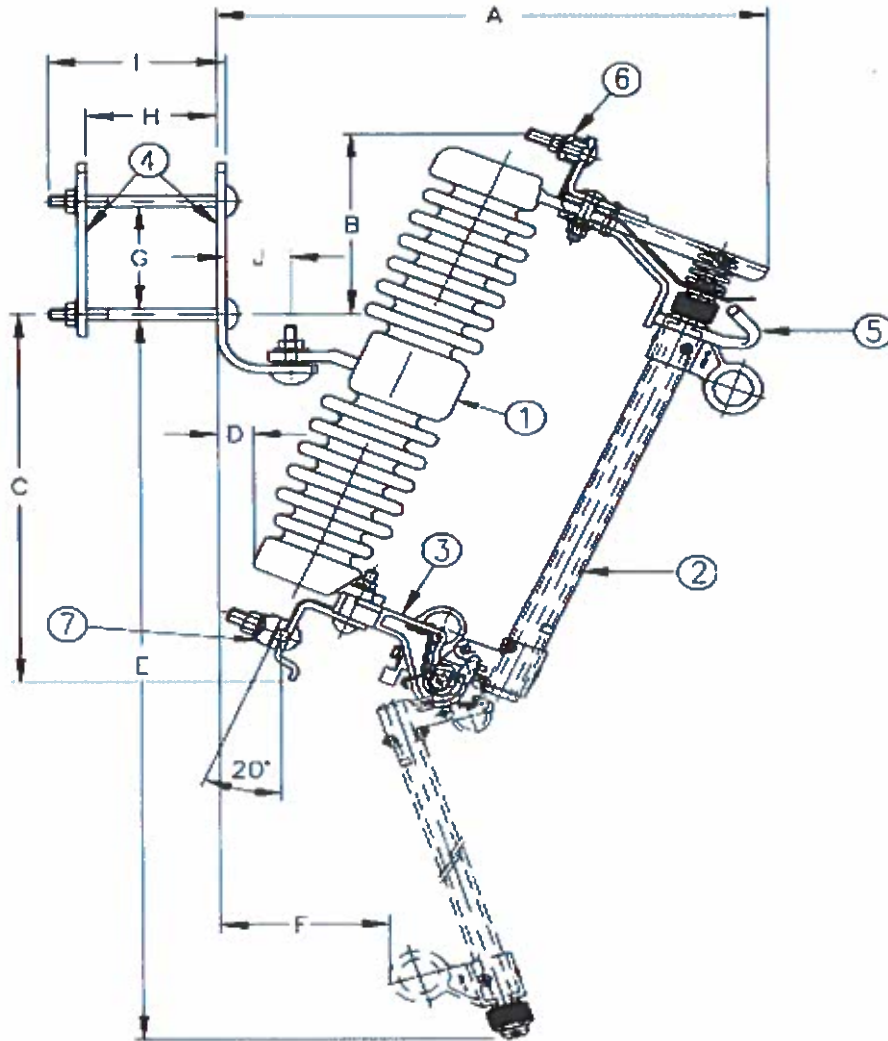

**Fig. 1. Typical arrangement of 11 kV Fuse Cutout.**

Type	Dimensions in millimetres Tolerance on dimensions - $\pm 10\text{mm}$										Approximate weight kg
	A	B	C	D	E	F	G	H	I	J	
11 kV drop out fuse	380	125	280	54	550	125	105 - 131	68 - 131	140	57	8.5

**Issued by:** Head of Section ,Standards Development

**Authorized by:** , Manager ,Standards

**Signed:**



**Signed:**

**Date:** 2016-06-03

**Date:** 2016-06-03



**TITLE:**  
**SPECIFICATION FOR  
11 kV EXPULSION FUSE  
CUT-OUT  
(Drop out type)**

Doc. No.	KP1/6C/13/TSP11/017
Issue No.	2
Revision No.	0
Date of Issue	2016-06-03
Page 11 of 19	

**4.3.1. Features**

The drop out fuse cutuot shall have the following major parts as per Fig. 1.

**1. Insulator and mounting insert.**

- a) The insulator shall be made of heavy duty and brown glazed silicon rubber or porcelain insulator as per caluse 4.2.10.
- b) Mounting insert shall be made of the insulator with a galvanized steel insert support.

**2. Fuse Tube**

The fuse tube shall consist of a vulcanized fiber lining tube, and a fiberglass-epoxy outer tube, to provide the superior strength necessary for the higher interrupting rating.

**3. Lifting eye and Hinge support**

- a) Lifting eye shall be suitable for a standard hook operating link stick.
- b) The hinge support shall employ a large pivot for the fuse-holder trunion and shall be made of stainless steel casting chosen for its strength and corrosion resistance

**4. Mounting Bracket**

This shall be a NEMA Duty Type-B mounting bracket. It shall be made of high strength structural galvanized steel.

**5. Upper backup , Top contact and Load break hook**

- a) Upper back up shall be made of galvanized steel with a high mechanical strength.
- b) The top contact shall be attached to the galvanized steel backup members. It shall combine the superior current carrying characteristics of silver plated copper and a high mechanical strength galvanized steel to provide an excellent contacting area with the fuse holder when in the closing condition.
- c) Load break hook shall be galvanized steel , standard type to be opened under load with the use of a load-buster, serving to guide the fuse holder during close operations.

**6. Upper and lower terminals**

These shall be made of tin-plate bronze and shall be parallel groove type terminals suitable for aluminium or copper conductor size ranges 22-160 mm<sup>2</sup>.

**4.3.2. Corossion Protection**

- 4.3.2.1. The hinge and latch mechanisms of the unit shall be constructed of corrosion resistant metals and shall include no ferrous parts other than stainless steel.

**Issued by:** Head of Section ,Standards Development

**Authorized by: ,** Manager ,Standards

**Signed:**

**Signed:**

**Date:** 2016-06-03

**Date:** 2016-06-03



**TITLE:**  
**SPECIFICATION FOR  
11 kV EXPULSION FUSE  
CUT-OUT  
(Drop out type)**

<b>Doc. No.</b>	KP1/6C/13/TSP11/017
<b>Issue No.</b>	2
<b>Revision No.</b>	0
<b>Date of Issue</b>	2016-06-03
Page 12 of 19	

- 4.3.2.2. All current carrying parts shall be of a high electrical conductivity, corrosion resistant metal.
- 4.3.2.3. All nuts, bolts and washers other than those associated with the mounting bracket shall be stainless steel. The bolts and washers shall be grade 316 and to avoid binding, the nuts shall be grade 304 and a suitable lubricant shall be applied to the threads of all stainless steel bolts before tightening. The lubricant shall not contain graphite.
- 4.3.2.4. All support brackets and other ferrous parts other than stainless steel shall be hot dip galvanized, with an average minimum zinc coating thickness of 80µm in accordance with ISO 1461.

**4.4. Quality Management System**

- 4.4.1. The supplier shall submit a quality assurance plan (QAP) that will be used to ensure that the design, material, workmanship, tests, service capability, maintenance and documentation, will fulfill the requirements stated in the contract documents, standards, specifications and regulations. The QAP shall be based on and include relevant parts to fulfill the requirements of ISO 9001:2008.
- 4.4.2. The Manufacturer's Declaration of Conformity to reference standards and copies of quality management certifications including copy of valid and relevant ISO 9001: 2008 certificate shall be submitted with the tender for evaluation.
- 4.4.3. The bidder shall indicate the delivery time of the fuse cutout manufacturer's monthly & annual production capacity and experience in the production of the type and size of fuse cutout being offered. A detailed list & contact addresses (including e-mail) of the manufacturer's previous customers outside the country of manufacture for the fuse cutout sold in the last five years together with reference letters from four of the customers shall be submitted with the tender for evaluation.

**5. TESTS AND INSPECTION**

- 5.1. Type tests, sampling tests and routine tests shall be done in accordance with the requirements of ISO 1461, IEC 60282-2, IEC 60437, IEC 60507, ANSI C 37.42, ANSI C 37.41 and this specification. It shall be the responsibility of the supplier to perform or to have performed all the tests specified.
- 5.2. Copies of Type Test Certificates & Type Test Reports issued by a third party testing laboratory that is accredited to ISO/IEC 17025 shall be submitted with the tender for the purpose of

<b>Issued by:</b> Head of Section ,Standards Development	<b>Authorized by:</b> , Manager ,Standards
<b>Signed:</b> 	<b>Signed:</b>
<b>Date:</b> 2016-06-03	<b>Date:</b> 2016-06-03



**TITLE:**  
**SPECIFICATION FOR  
11 kV EXPULSION FUSE  
CUT-OUT  
(Drop out type)**

Doc. No.	KP1/6C/13/TSP11/017
Issue No.	2
Revision No.	0
Date of Issue	2016-06-03
Page 13 of 19	

technical evaluation. A copy of the accreditation certificate to ISO/IEC 17025 for the testing laboratory shall also be submitted (all in English language).

- 5.3. Copies of type test reports to be submitted with the tender (by bidder) for evaluation shall be as stated:
- a) Dielectric tests to IEC 60282-2 - clause 11.
    - (i) Power frequency withstand (1minute dry and wet)
    - (ii) Lightning impulse withstand (1.2/50µsec) tests -Table 2, no. 4 of this specification.
  - b) Interrupting capacity test to IEC 60282-2 - clause 13.
  - c) Radio interference test to IEC 60437.
  - d) Temperature rise tests to IEC 60282-2 - clause 12.
  - e) Pollution performance test as per IEC 60507.
    - (i) Salt spray corrosion performance tests for 1000 hours.
    - (ii) Solid layer pollution test.
  - f) Expendable caps shall be subject to a static relief pressure test to ANSI C 37.42 - clause 2.2.7.
  - g) Load break tests to ANSI C 37.41, clause 7. The tests shall be made with the manufacturers recommended portable load break device
- 5.4. The fuse cutouts shall be subject to acceptance tests at the manufacture's works before dispatch. Acceptance tests shall be witnessed by two Engineers appointed by The Kenya Power and Lighting Company Limited (KPLC).
- 5.5. Tests to be witnessed by KPLC Engineers at the factory before shipment shall be in accordance with ISO 1461, IEC 60282-2, IEC 60437, IEC 60507, ANSI C 37.42, ANSI C 37.41 and this specification and shall include:
- a) Manual Operation tests
  - b) Dielectric tests,
  - c) Thermal Cycle tests,
  - d) Bolt Torque tests,
  - e) Insulator tests,
  - f) Power frequency reference or low current tests.
  - g) Galvanization tests.
- 5.6. On receipt of the fuse cutouts, KPLC will inspect them and may perform or have performed any of the relevant tests in order to verify compliance with the specification. The supplier shall replace without charge to KPLC, fuse cutouts which upon examination, test or use fail to meet any or all of the requirements in the specification.

Issued by: Head of Section ,Standards Development

Authorized by:, Manager ,Standards

Signed:

Signed:

Date: 2016-06-03

Date: 2016-06-03



**TITLE:****SPECIFICATION FOR  
11 kV EXPULSION FUSE  
CUT-OUT  
(Drop out type)**

Doc. No.

KP1/6C/13/TSP11/017

Issue No.

2

Revision No.

0

Date of Issue

2016-06-03

Page 14 of 19

**6. MARKING, LABELLING AND PACKING****6.1. Marking**

The following information shall be marked indelibly and legibly on each fuse cutout in English language:

- a) Manufacturer's name or trademark;
- b) Manufacturer's type designation;
- c) The year of manufacture;
- d) Rated current;
- e) Rated voltage and insulation withstand.
- f) The letter, "KPLC".

**NOTE:** *The marking shall be on the fuse base as well as on the fuse carrier.*

**6.2. Packing**

6.2.1. Each dropout fuse cutout shall be packed individually in a strong non-returnable wooden crate/ card board box in such manner to prevent damage to components during transportation and handling up to installation site.

6.2.2. Packing shall be designed to prevent entry of dust, ingress of moisture and other foreign materials. The mounting bracket may be packed separately as per the manufacturer's discretion. Each container shall have the following information stenciled on it in English language.

- a) Manufacture's name.
- b) Country of origin.
- c) KPLC item number
- d) KPLC purchase order number.
- e) Weight in kilogram.
- f) Handling instruction.
- g) Voltage and current rating.
- h) The word, "The Property of Kenya Power and Lighting Company".

**NOTE:** *Dropout fuse cutouts shall not be packed in any organic material.*

**7. DOCUMENTATION**

7.1 The bidder shall submit its tender complete with technical documents required by Annex A (Guaranteed Technical Particulars) for tender evaluation. The documents to be submitted (all in English language) for tender evaluation shall include the following:

- a) Guaranteed Technical Particulars fully filled and signed by the manufacturer;

**Issued by:** Head of Section ,Standards Development**Authorized by:** , Manager ,Standards**Signed:****Signed:****Date:** 2016-06-03**Date:** 2016-06-03

<b>TITLE:</b>  <b>SPECIFICATION FOR 11 kV EXPULSION FUSE CUT-OUT (Drop out type)</b>	<b>Doc. No.</b>	KP1/6C/13/TSP11/017
	<b>Issue No.</b>	2
	<b>Revision No.</b>	0
	<b>Date of Issue</b>	2016-06-03
	Page 15 of 19	

- b) Copies of the Manufacturer's catalogues, brochures, drawings and technical data;
- c) Sales records for previous five years and reference letters from at least four of the customers;
- d) Details of manufacturing capacity and the manufacturer's experience;
- e) Copies of required type test certificates and type test reports by a third party testing laboratory accredited to ISO/IEC 17025;
- f) Copy of accreditation certificate to ISO/IEC 17025 for the third party testing laboratory;
- g) Manufacturer's warranty and guarantee;
- h) Manufacturer's letter of authorization, copy of the manufacturer's ISO 9001:2008 certificate and other technical documents required in the tender.

7.2 The successful bidder (supplier) shall submit the following documents/details (from the manufacturer as per tender) to The Kenya Power & Lighting Company for approval before manufacture:

- a) Guaranteed Technical Particulars fully filled and signed by the manufacturer;
- b) Design drawings & construction details of the fuse cutout including 3-D views;
- c) Quality assurance plan (QAP) that will be used to ensure that the design, material, workmanship, tests, service capability, maintenance and documentation will fulfill the requirements stated in the contract documents, standards, specifications and regulations. The QAP shall be based on and include relevant parts to fulfill the requirements of ISO 9001:2008;
- d) Test Program to be used after manufacture;
- e) Marking details and method to be used in marking each fuse cutout;
- f) Manufacturer's undertaking to ensure adequacy of the design, adherence to applicable regulations, standards and specification, ensure good workmanship and good engineering practice in the manufacture of the fuse cutout for The Kenya Power and Lighting Company Limited;
- g) Packaging details (including packaging materials and marking and identification of component packages).

**NOTE:** *The drawings to be submitted by the supplier to KPLC for approval before manufacture shall be in standard format clearly indication drawing number, parts list with material details & quantities, standard of manufacture, ratings, approval details and identity of the manufacturer (as per manufacturer's authorization submitted during tendering).*

<b>Issued by:</b> Head of Section ,Standards Development	<b>Authorized by:.</b> Manager ,Standards
<b>Signed:</b> 	<b>Signed:</b> 
<b>Date:</b> 2016-06-03	<b>Date:</b> 2016-06-03

<b>TITLE:</b>  <b>SPECIFICATION FOR 11 kV EXPULSION FUSE CUT-OUT (Drop out type)</b>	<b>Doc. No.</b>	KP1/6C/13/TSP11/017
	<b>Issue No.</b>	2
	<b>Revision No.</b>	0
	<b>Date of Issue</b>	2016-06-03
	Page 16 of 19	

**ANNEX A: SCHEDULE OF GUARANTEED TECHNICAL PARTICULARS (GTPs) FOR OFFERED EXPULSION FUSE CUTOUTS**

*(to be filled and signed by the Manufacturer and submitted together with relevant copies of the Manufacturer's catalogues, brochures, drawings, technical data, sales records for past five years, four customer reference letters, details of manufacturing capacity, the manufacturer's experience, copies of complete type test reports and accreditation certificate to ISO/IEC 17025 for the third party testing laboratory for tender evaluation, all in English Language)*

**TENDER NO. ....BIDDER'S NAME & ADDRESS .....**

Clause	Description	GTPs offered
	Name of Manufacturer & Country of manufacture of the expulsion fuse cutouts being offered	
	Type/Model Reference Number	
1	Scope: Supplier to ensure adequacy of the design, good workmanship, good engineering practice and adherence to standards, specifications and applicable regulations in the manufacture of the expulsion fuse cutouts for KPLC	
2	Design standards complied with	
3	Terms and Definitions	
4	Requirements	
4.1	System conditions	
4.2	Design and construction	
	4.2.1 General	
	4.2.1.1 - 4.2.1.4	
	4.2.2 Operation	
	4.2.2.1 - 4.2.2.2	
	4.2.3 Mounting	
	a. Steel cross-arm mounting	
	b. Pole mounting	
	4.2.4 Contacts	
	4.2.4.1 - 4.2.4.2	
	4.2.5 Terminal connection	
	4.2.5.1 - 4.2.5.4	
	4.2.6 Vibration	
	4.2.7 Bird/Fauna/Vermin Proofing	
	4.2.7.1 - 4.2.7.2	
	4.2.8 Fuse Link Installation	
	4.2.8.1 - 4.2.8.4	
	4.2.9 Earthing attachment	

**Issued by: Head of Section ,Standards Development**

**Authorized by: , Manager ,Standards**

**Signed:**

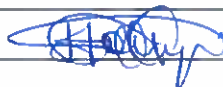

**Signed:**

**Date: 2016-06-03**

**Date: 2016-06-03**

<b>TITLE:</b>  <b>SPECIFICATION FOR 11 kV EXPULSION FUSE CUT-OUT (Drop out type)</b>	<b>Doc. No.</b>	KP1/6C/13/TSP11/017
	<b>Issue No.</b>	2
	<b>Revision No.</b>	0
	<b>Date of Issue</b>	2016-06-03
	Page 17 of 19	

Clause	Description	GTPs offered
	4.2.9.1 - 4.2.9.4	
	4.2.10 Insulators	
	4.2.10.1 - 4.2.10.2	
4.3	<b>Rating</b>	
	<b>Fuse-base and fuse carrier</b>	
	Rated voltage, kV	11
	Highest Voltage, kV	12
	Rated continuous current, A	400
	Insulation level	
	a) Dry impulse withstand (1.2/50µs) voltage (positive and negative polarity) (peak)	
	(i) Across the isolating distance of the fuse base, kVpeak	95
	(ii) To earth and between poles, kVpeak	85
	b) Wet one (1) minute power frequency withstand voltage (rms)	
	(i) Across isolating distance of the fuse base, kVrms	38
	(ii) To earth and between poles, kVrms	32
	Rated short circuit withstand current of fuse base and carrier, kA	16 (3s)
	Radio interference voltage at 1 MHz, µV	200
	Total creepage distance, 31mm/kV, mm ?	400 ?
	Mounting angle degrees	10 - 20
	Interrupting rating	
	(i) Symmetrical interrupting rating (minimum) rms, kA	8
	(ii) Asymmetrical interrupting rating (minimum) rms, kA	9.6
	X/R ration	
4.3.1	<b>Features</b>	
	1. Insulator	
	2. Fuse tube	
	3. Lifting eye and hinge support	
	4. Mounting bracket	
	5. Upper backup, Top contact and Load break hook	
	6. Upper and Lower terminals	
4.3.2	<b>Corrosion protection</b>	
	4.3.2.1 – 4.3.2.4	
4.3.3	<b>Dimensions</b>	
	A, mm	380
	B, mm	125
	C, mm	280
	D, mm	54

Issued by: Head of Section ,Standards Development

Authorized by:, Manager ,Standards

Signed:



Signed:

Date: 2016-06-03

Date: 2016-06-03

**TITLE:**

**SPECIFICATION FOR  
11 kV EXPULSION FUSE  
CUT-OUT  
(Drop out type)**

Doc. No.	KP1/6C/13/TSP11/017
Issue No.	2
Revision No.	0
Date of Issue	2016-06-03
Page 18 of 19	

Clause	Description	GTPs offered
	E, mm	550
	F, mm	125
	G, mm	105 - 131
	H, mm	68 - 131
	I, mm	140
	J, mm	57
	Approximate weight	8.5
4.5	Quality Management System	
	Quality Assurance Plan	
	Copy of ISO 9001:2008 Certificate	
	Manufacturer's experience	
	Manufacturing Capacity (units per month)	
	List of previous customers	
	Customer reference letters	
5.1	Test standards and responsibility of carrying out tests	
5.2	Copies of Type Test Reports submitted with tender	
5.3	Acceptance tests to be witnessed by KPLC at factory before shipment	
5.4	Test reports to be submitted by supplier to KPLC for approval before shipment	
5.5	Replacement of rejected fuse cutouts	
6.1	Marking	
6.2	Packing	
7.1	Documents submitted with tender	
7.2	Documents to be submitted by supplier to KPLC for approval before manufacture	
	Statement of compliance to specification	

.....  
**Manufacturer's Name, Signature, Stamp and Date**

**Issued by:** Head of Section ,Standards Development

**Authorized by:** , Manager ,Standards

**Signed:**



**Signed:**

**Date:** 2016-06-03

**Date:** 2016-06-03



<b>TITLE:</b>  <b>SPECIFICATION FOR  11 kV EXPULSION FUSE  CUT-OUT  (Drop out type)</b>	<b>Doc. No.</b>	KP1/6C/13/TSP11/017
	<b>Issue No.</b>	2
	<b>Revision No.</b>	0
	<b>Date of Issue</b>	2016-06-03
	Page 19 of 19	

**ANNEX B: LIST OF CONTRACTORS**

S/N	Item	Type designation	Name of supplier	Place of manufacture	Place of testing inspection
1	Insulators				
2	Base parts				
3	Springs				
4	Fuse holder				

<b>Issued by:</b> Head of Section ,Standards Development	<b>Authorized by: ,</b> Manager ,Standards
<b>Signed:</b> 	<b>Signed:</b>
<b>Date:</b> 2016-06-03	<b>Date:</b> 2016-06-03

10

11

12